

DETERMINING PATTERNS OF VERTICAL LOAD ON THE PROTOTYPE OF A REMOVABLE MODULE FOR LONG-SIZE CARGOES

Glib Vatulia

Doctor of Technical Sciences, Professor, Vice-Rector for Research*

Alyona Lovska

Corresponding author

Doctor of Technical Sciences, Associate Professor

Department of Wagon Engineering and Product Quality*

E-mail: alyonaLovskaya.vagons@gmail.com

Mykhailo Pavliuchenkov

PhD, Associate Professor

Department of Structural Mechanics and Hydraulics*

Volodymyr Nerubatskyi

PhD, Associate Professor

Department of Electrical Power Engineering,

Electrical Engineering and Electromechanics*

Andrii Okorokov

PhD, Associate Professor

Denys Hordiienko

Senior Engineer

ELAKS PJSC

Akademika Proskury str., 1, Kharkiv, Ukraine, 61085

Roman Vernigora

PhD, Associate Professor

Department of Railway Stations and Units***

Irina Zhuravel

PhD**

*Ukrainian State University of Railway Transport

Feuerbakh sq., 7, Kharkiv, Ukraine, 61050

Department of Management of Operational Work*

***Ukrainian State University of Science and Technologies

Lazaryan str., 2, Dnipro, Ukraine, 49010

The object of this study is the processes of occurrence, exposure to, and redistribution of loads in the supporting structure of a removable module for the transportation of long cargoes.

To adapt platform cars to the transportation of long loads, it is proposed to introduce a removable module with elastic-friction connections in the structure.

In order to select the optimal profiles for the removable module, in terms of minimal material consumption, the calculation was carried out in the Lira software package. Based on the calculation results, a spatial model of the concept of the removable module was built.

To determine the dynamic loads that act on the platform car loaded with a removable module, a mathematical simulation was carried out. It was established that the use of elastic-friction links in the structure of the removable module helps reduce its dynamic load, as well as the platform car, by 4.6%. The resulting acceleration was taken into account when calculating the strength of the removable module. The calculation results showed that the strength of the removable module under operational loads is ensured.

A feature of the reported results is that the proposed design of a removable module makes it possible not only to adapt the platform car to the transportation of long loads but also to reduce its load in operation.

The scope of practical application of the results includes the engineering industry, in particular, railroad transport. Worth noting is that the conditions for the practical use of the results imply the introduction of elastic-friction links in the structure of the removable module.

The reported research will contribute to compiling recommendations for the design of modern vehicle structures, in particular removable type, as well as for improving the efficiency of rail transportation

Keywords: transport mechanics, removable module, supporting structure, structural strength, structural adaptation

Received date 19.08.2022 **How to Cite:** Vatulia, G., Lovska, A., Pavliuchenkov, M., Nerubatskyi, V., Okorokov, A., Hordiienko, D., Vernigora, R., Zhuravel, I. (2022).

Accepted date 07.11.2022

Determining patterns of vertical load on the prototype of a removable module for long-size cargoes.

Published date 30.12.2022

Eastern-European Journal of Enterprise Technologies, 6 (7 (120)), 21–29. doi: <https://doi.org/10.15587/1729-4061.2022.266855>

1. Introduction

Providing the efficiency of the machine-building industry necessitates the commissioning of modern vehicle designs. The most competitive component of the machine-building industry over a long time is railroad transport, which accounts for the essential segment of freight and passenger transportation.

To maintain leadership positions and increase the efficiency of railroad transportation, situational adaptation of existing rolling stock for the transportation of the assigned range of cargoes is relevant [1, 2]. One of the options for achieving this is the introduction of removable modules [3, 4]. These modules are installed on open cars, in particular, platform cars, thereby adapting them to the transportation of relevant cargoes. The modules on the

frame of the platform cars are fixed mainly through fittings placed in the corner zones.

One of the most common types of cargoes that are transported on platform cars are long ones, for example, bundles of timber, round pipes, etc. Their transportation on universal platform cars involves wooden vertical racks installed in timber brackets. It is important to note that not all platform cars are equipped with such elements, which leads to a shortage of rolling stock for appropriate cargo transportation. In addition, due to the effect of cyclic operational loads, in the event of defects in the racks, there is a possibility to compromise the reliability of the transportation of cargoes fixed according to this scheme. The consequences may include accidents on railroad transport. Therefore, it is important to design and put into operation removable modules that will contribute not only to the adaptation of platform cars to the transportation of long loads but also to the safety of their movement as part of trains.

2. Literature review and problem statement

A large body of research considers the issues of improving the supporting structures of platform cars to increase the efficiency of their operation. At the present stage of development of the transport industry, the issues of improvements and upgrades should be accompanied by the possibility of situational adaptation of cars, by improving their strength, including reducing the dynamic load.

Thus, for example, paper [5] justifies the modernization of the car for the transportation of oil bitumen for a platform car to transport long loads. The features of this modernization are considered, and the methodology for determining the strength of such a car under the main operating modes is given. The expediency of structural improvement of the platform car has been proven. It is important to note that the proposed modernization, in this case, is narrow because it does allow for the implementation of situational adaptation of the car to the range of transported cargoes whose market may vary depending on demand.

The strength indicators of a long-based platform car, which can be adapted for the transportation of removable vehicle units are determined in paper [6]. To this end, it is proposed to install special super-structures on the car. This solution makes it possible to transport long loads on the platform car. The paper also reports the results of the calculation of the strength of the frame of the platform car, subject to the proposed improvement. However, it would be advisable to provide solutions in the design of the platform car that will help reduce its dynamic load. After all, we are talking about the long-base design of the car, which during operation is exposed to the constant effect of cyclic loads. This causes the appearance of defects in it. However, the authors solved this issue by strengthening it, which certainly increases the weight of the structure.

Analysis of the dynamic load of the platform car for the transportation of long loads is carried out in paper [7]. The research was involved theoretical and experimental methods. Natural frequencies and shapes of oscillations of the supporting structure of the platform car were determined. The reported studies made it possible to refine theoretical models in order to improve their accuracy. At the same time, the use of these models to improve the design of the platform car was not carried out by the authors.

Features of modernization of the platform car for transportation of vehicles of modular type are covered in [8]. The authors proposed the use of a removable frame to accommodate vehicles. The results of the calculation of the frame strength are given. It has been established that the proposed solutions for its implementation are expedient. However, this modernization is narrowly focused and makes it possible to adapt the car only for the transportation of a specific cargo.

The supporting structure of the platform car to enable container transportation as part of combined trains is improved in paper [9]. This improvement involves the installation of vertical super-building on the supporting structure of the platform car, which will also contribute to the possibility of long load transportation on it. The proposed solution is confirmed by theoretical calculations for strength. The built models were verified by comparing two samples acquired from mathematical modeling and computer simulation. At the same time, the authors did not determine the strength of the improved structure of the platform car during the transportation of long loads, that is, only containers were studied.

The study of structural features of long-based platform cars is reported in work [10]. The results of determining the main indicators of the strength of their supporting structures under operational loads are given. Promising ways to improve the strength of platform cars have been identified. It is important to note that the authors do not indicate the possibility of reducing their dynamic load to improve strength.

The considered structural solutions for the improvement of the supporting structures of platform cars imply the need for their modernization, which requires appropriate capital investments. In addition, these upgrades are narrowly focused since they have the feasibility for transporting specific types of cargo. That is why it is more rational and relevant to use removable modules that operate on the principle of interchangeable bodies. Currently, there is a wide variety of structural features and technology for using such modules, including for long loads.

For example, in [11], the author proposed a freight unit that makes it possible to adapt the platform car for the transportation of long loads. The main structural features of the freight unit were analyzed. The useful result from its use was indicated. The disadvantage of this freight unit is that it does not make it possible to reduce the dynamic load of the supporting structure of the platform car under operational modes.

A structure of the device for placing and securing cargoes on the platform car is proposed in paper [12]. The device includes vertical risers, which are equipped with nuts with screws attached to them, as well as guides. Locks are installed in the guides. At the same time, side risers and flexible fasteners can be lined with cushioning linings from the side of the inner loading opening of the platform. It is important to note that this device does not reduce the dynamic load of the platform car under operating conditions.

In addition, the design of a freight unit, which makes it possible to adapt the platform car to the transportation of long loads is proposed in [13]. The structural features of the freight unit, as well as its distinctive features from existing analogs, are considered. The use of the freight unit provides the possibility of intermodal and unimodal transportation of timber, lumber, rolled metal, pipes, and other cargoes. However, the design of this freight unit does not contribute to the reduction of dynamic load of the platform car under operating conditions.

Our review of literary sources [5–13] shows that the improvement of the supporting structures of platform cars to

increase the efficiency of their operation is a relevant issue. At the same time, measures to reduce the dynamic load of platform cars during the transportation of long loads have not yet been given due attention. This circumstance pre-determines the need for research in this area.

3. The aim and objectives of the study

The aim of this study is to determine the patterns of vertical load on the concept of a removable module for the transportation of long loads with elastic-friction links in the structure. This will contribute to the adaptation of platform cars to the transportation of long loads, as well as reduce the load on their supporting structures under operation conditions.

To accomplish the aim, the following tasks have been set:

- to offer the concept of a removable module for the transportation of long loads;
- to determine the dynamic load on the removable module placed on the platform car;
- to determine the basic indicators of the strength of the removable module.

4. The study materials and methods

The object of this study is the processes of occurrence, exposure to, and redistribution of loads in the supporting structure of the removable module for the transportation of long loads.

The main hypothesis of the study assumes that reducing the load on the removable module under operating modes, and, accordingly, the platform car, is possible due to the use of elastic-friction links in its structure.

To adapt platform cars for the transportation of long loads, the introduction of a removable module is proposed (Fig. 1). The structure of the removable module includes main longitudinal beams 1, side beams 2, transverse beams 3, intermediate transverse beams 4, as well as vertical racks 5. The removable module on the frame of the platform car is fastened by corner fittings 6.

When designing the module, the standard sizes of fittings are taken into account, in accordance with DSTU ISO 1496-1: 2013. The analog of this document is “ISO 668:1995 Series 1 freight containers – Classification, dimensions and ratings”.

A feature of the removable module is that its constituent frames (bottoms) are made of open profiles, which host elastic elements. Elastic elements can be represented by springs, a material with elastic characteristics, devices that realize the elastic effect. From a top, the elastic elements are blocked by a U-shaped profile. This solution makes it possible to reduce the dynamic loads that act on the module due to the elastic-dissipative forces arising from fluctuations in the jumping of the car (Fig. 2). These forces arise due to friction of the vertical parts of the U-shaped profile with the vertical parts of the profile in which the elastic elements are placed. According to our earlier studies, it was established that the use of elastic-friction links helps reduce the dynamic load on cars by 15–20 %.

A distinctive feature of the proposed solution from that specified in the Patent of Ukraine for utility model No. 146847 is that the upper part of the node is represented

by a U-shaped profile. Due to this, the friction area between the components of the beam increases, and, accordingly, the efficiency of its work.

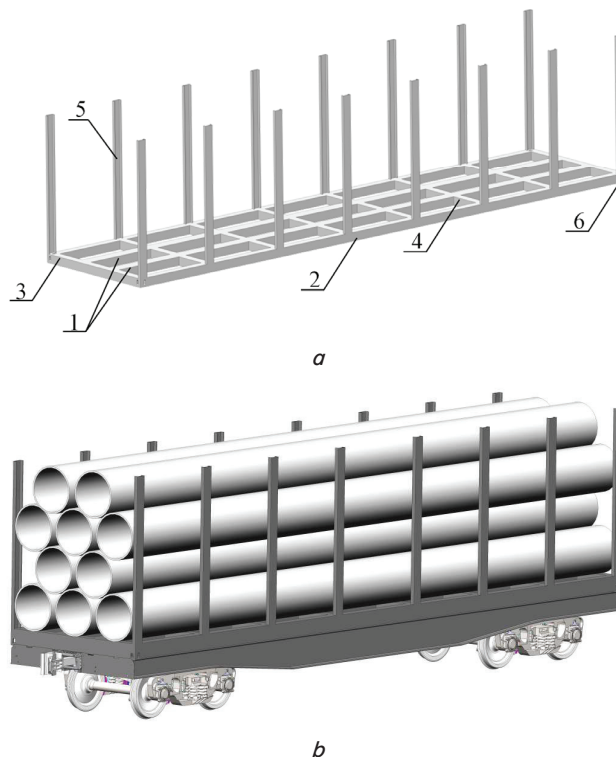

Fig. 1. Removable module for transporting bundles of timber: *a* – general view; *b* – arrangement on the platform car

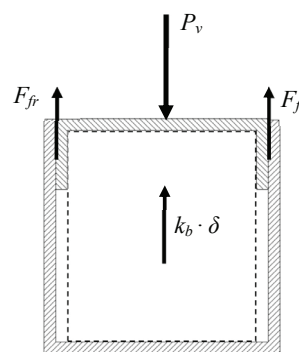

Fig. 2. Scheme of action of forces on the horizontal beam of the removable module: P_v – vertical force due to the weight of the cargo placed in the module; F_{fr} – friction force; k_b – stiffness of elastic elements arranged in the beam; δ – the amount of compression of elastic elements under the action of force P_v

To select the optimal profiles of the removable module, in terms of the minimum material consumption, the strength is calculated. In this case, the Lira software package (Ukraine) was applied [14, 15]. The removable module is considered as a rod system on hinged-fixed supports at the corners. It is taken into account that the vertical load P_v acts on the module. The P_r load, uniformly distributed for height, was applied to the racks (Fig. 3).

The load value P_r for the height of the rack was determined in accordance with the “Local technical conditions for the arrangement and fastening of round timber with a length of 3.0, 4.0, 6.0 m on a specialized platform of the model 13-9997”.

$$P_r = \frac{\Delta F_i}{L_r}, \tag{1}$$

ΔF_i is the transverse inertial force from the mass of the stack, taking into account the arrangement along the length of the car, kN.

In this case,

$$\Delta F_i = n \cdot (F_i + W') - F_{fr}^i, \tag{2}$$

n is the coefficient, which is calculated when compiling technical conditions for the platform car;

F_i is the transverse inertial load from the mass of the stack of cargo, taking into account its arrangement along the length of the car and the action of centrifugal force;

W' is wind load, which acts on the cargo;

F_{fr}^i is the friction force acting on the stack of cargo, taking into account its arrangement along the length of the car in the transverse direction.

When carrying out calculations, the height of the racks was assumed to be equal to 3,169 m.

To determine the dynamic load that acts on the removable module on the platform car, the calculation is carried out. In this case, jumping fluctuations are taken into account as the most common type of oscillations in car operation [16, 17]. The estimation scheme of the platform car is shown in Fig. 4. It consists of four bodies: a supporting structure with the module, two bogies, and a load. When modeling, the load is considered as a homogeneous body. It is taken into account that the platform car moves along a butt track with elastic-viscous properties.

With this in mind, the movement of the car is described by a system of differential equations:

$$\left\{ \begin{aligned} M_1 \cdot \frac{d^2}{dt^2} q_1 + C_{1,1} \cdot q_1 + C_{1,2} \cdot q_2 + C_{1,3} \cdot q_3 = & \\ = -F_{FR} \cdot \left(\text{sign} \left(\frac{d}{dt} \delta_1 \right) + \text{sign} \left(\frac{d}{dt} \delta_2 \right) \right) - & \\ - (F_{fr} \cdot \text{sign}(\dot{q}_1 - \dot{q}_4) + k_b \cdot (q_1 - q_4)), & \\ M_2 \cdot \frac{d^2}{dt^2} q_2 + C_{2,1} \cdot q_1 + C_{2,2} \cdot q_2 + C_{2,3} \cdot q_3 + B_{2,2} \cdot \frac{d}{dt} q_2 = & \\ F_{FR} \cdot \text{sign} \left(\frac{d}{dt} \delta_1 \right) + k(\eta_1 + \eta_2) + \beta \left(\frac{d}{dt} \eta_1 + \frac{d}{dt} \eta_2 \right), & \\ M_3 \cdot \frac{d^2}{dt^2} q_3 + C_{3,1} \cdot q_1 + C_{3,2} \cdot q_2 + C_{3,3} \cdot q_3 + B_{3,3} \cdot \frac{d}{dt} q_3 = & \\ = F_{FR} \cdot \text{sign} \left(\frac{d}{dt} \delta_2 \right) + k(\eta_3 + \eta_4) + \beta \left(\frac{d}{dt} \eta_3 + \frac{d}{dt} \eta_4 \right), & \\ M_4 \cdot \ddot{q}_4 = (F_{fr} \cdot \text{sign}(\dot{q}_1 - \dot{q}_4) + k_b \cdot (q_1 - q_4)) - M_4 \cdot g, & \end{aligned} \right. \tag{3}$$

where M_i is the inertial coefficients of the elements of the oscillatory system (supporting structure of the platform car with the module, two bogies, and a conditional cargo); C_{ij} is the characteristic of the elasticity of the elements of the oscillatory system, which are determined by the values of the coefficients of spring stiffness k_B ; B_{ij} is the scattering function; q_i – generalized coordinates corresponding to the translational movement relative to the vertical axis, respectively, of the supporting structure of the platform car with a removable module, the first and second bogie, as well as the cargo; k is the track rigidity; k_b is the stiffness of elastic elements in the module; β – damping coefficient; F_{FR} – ab-

solute friction force in the spring kit; F_{fr} – friction forces in the components of the module; δ_i is the deformation of elastic elements of spring suspension; η_i – track unevenness.

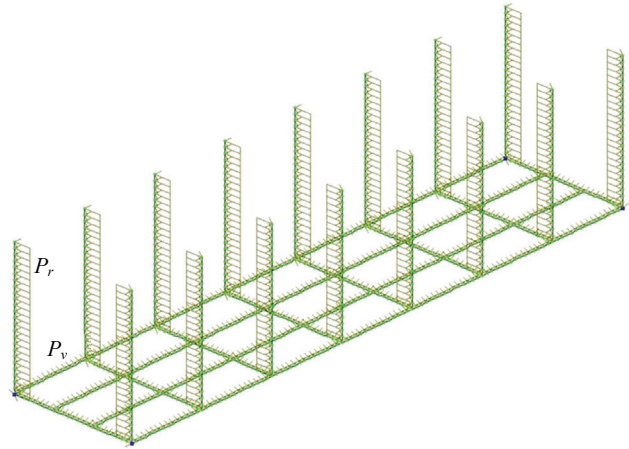

Fig. 3. Estimation scheme of the removable module

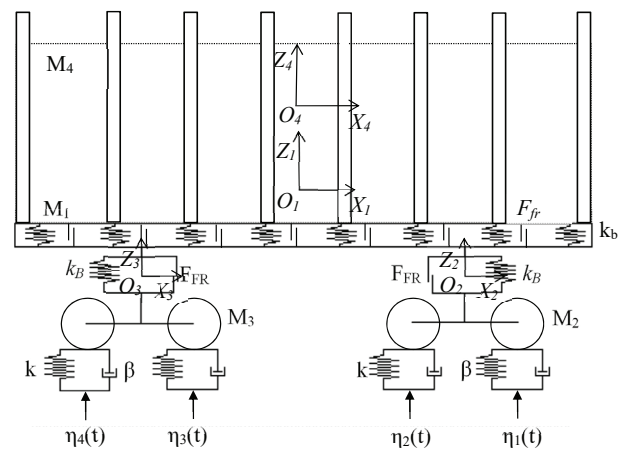

Fig. 4. Estimation scheme of the platform car with a removable module

The input parameters of the model are the technical characteristics of the platform car, the removable module, as well as the unevenness of the track. Track unevenness was described by a periodic function [18–20].

The resulting acceleration value is taken into account when calculating the strength of the removable module. In this case, a finite-element method was used, which is implemented in the SolidWorks Simulation software package (France). The construction of a spatial model of the removable module was carried out in the SolidWorks software (France).

When drawing up the estimation scheme, it is taken into account that the vertical load P_v on the removable module, as well as the friction force P_{fr} (Fig. 5). In this case, the vertical load includes a vertical static component and a dynamic one, calculated according to model (3). In addition, a uniformly distributed load P_r from the transported cargo was applied to the vertical racks of the removable module.

The removable module was fixed in the zones of its support on the platform car [21, 22]. Isoparametric tetrahedra were used to construct a finite-element model of the removable module [23–25]. The number of nodes of the model was 21695, elements – 66537. The maximum size of the element is 110 mm, the minimum is 22 mm. Steel grade 09G2S is intended as a structural material, which is typical in car

building for the manufacture of load-bearing structures of vehicles [26, 27]. This steel grade has a modulus of elasticity of $2.1 \cdot 10^5$ MPa, a tensile strength of 490 MPa, a yield strength of 345 MPa.

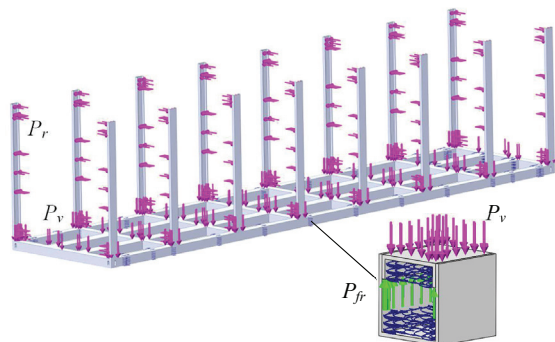

Fig. 5. Estimation scheme of the removable module

5. Results of determining the patterns of vertical load on the removable module for long loads

5.1. Devising a concept for a removable module for the transportation of long loads

On the basis of the calculations carried out in accordance with the scheme shown in Fig. 3, we have built the diagrams of bending moments that act on the components of the removable module. For better visualization of our results, Fig. 6, 7 separately show the diagrams of bending moments, which act, respectively, on the frame of the module, and the rack.

The maximum bending moment acting on the frame of the removable module occurs in the intermediate transverse beams and is equal to 309 kN·m (Fig. 6). In the intermediate beams, it was 309 kN·m. The value of the bending moment in the longitudinal beams is 283 kN·m. The maximum value of the bending moment in vertical racks is observed in the zones of their interaction with the frame and is 307 kN·m (Fig. 7).

According to the maximum values of the bending moments, the moment of resistance of the components of the module was determined [28, 29]

$$W = \frac{M}{[\sigma]}, \tag{4}$$

where M is the bending moment; $[\sigma]$ – permissible stresses.

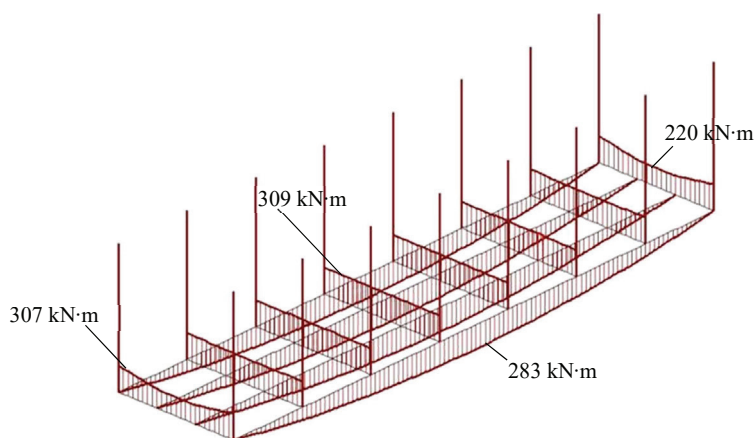

Fig. 6. Diagram of bending moments that act on the frame of the removable module

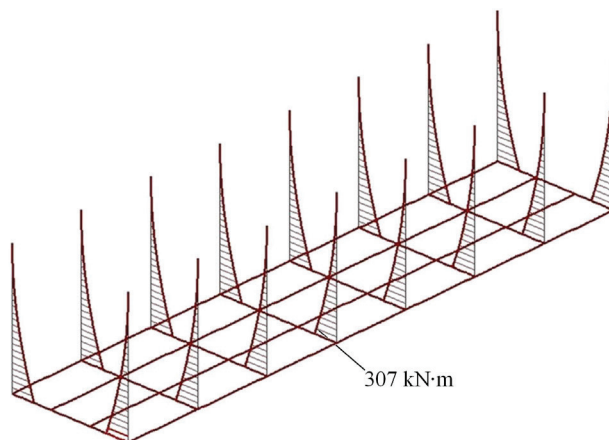

Fig. 7. Diagram of bending moments that act on the racks of the removable module

With this in mind, the calculated value of the moment of resistance for the components of the frame was $W=1471.4 \text{ cm}^3$, and for racks – $W=1461.9 \text{ m}^3$.

Based on our calculations, a profile formed by three sheets, 9 mm thick, was chosen as profiles for the frame of the removable module (Fig. 8, a).

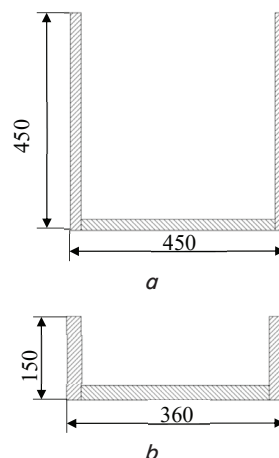

Fig. 8. Cross-section of module components: a – frame; b – racks

With regard to racks – a profile formed by three sheets; 12 mm thick (Fig. 8, b). When making calculations, the margin ratio is taken to be 1.3.

5.2. Determining the dynamic load on the removable module

To determine the dynamic loads that act on the proposed concept of the removable module, mathematical modeling was carried out. It is taken into account that the removable module is located on the platform car of the model 13-401M with fitting stops, moving at a speed of 80 km/h. That is, the operational speed of movement is taken into account. The rigidity of the track is assumed to be equal to 1000 kN/m, the coefficient of viscous resistance is 200 kN·s/m [18]. The depth of the irregularity is 0.01 m, and the length is 3 m.

Mathematical model (3) was solved by the Runge-Kutta method [30–32]. In this case, the

initial movement and speed are set to zero [33–35]. The results of the calculation are shown in Fig. 9, 10.

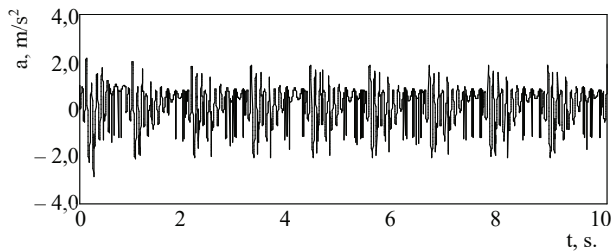

Fig. 9. Accelerations that act on the supporting structure of the platform car with a removable module

It was established that the maximum acceleration acting on a platform car with a removable module is 2.86 m/s^2 . It is important to note that the resulting acceleration is 4.6 % lower than that which acts on the supporting structure of the platform-car, loaded with a module without elastic-friction links. The acceleration that acts on the bogies is 9.9 m/s^2 . Movement of the platform car in the loaded state in accordance with DSTU 7598:2014. Freight cars. General requirements for calculations and design of new and modernized cars of track 1520 mm (non-self-propelled) is rated as “good”. An analog of this standard is “EN 12663–2. Railroad applications – structural requirements of railroad vehicle bodies – Part 2: Freight cars. B., 2010. 54 p.”.

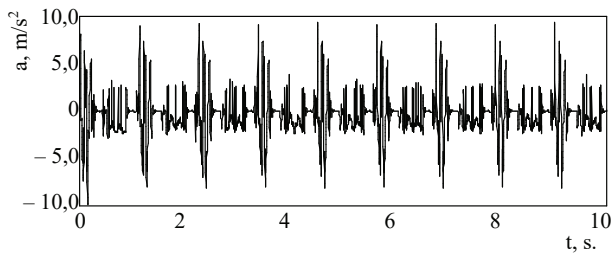

Fig. 10. Accelerations that act on the bogie

The calculation is implemented in relation to other speeds of movement of the platform car. The results of the calculations are given in Table 1.

Table 1

Accelerations that act on a platform car with a removable module

Speed, km/h	80	90	100	110	120
Acceleration in the center of mass, m/s^2	2.86	2.84	3.07	2.7	3.12
Bogie acceleration, m/s^2	9.9	11.1	12.2	13.5	14.2

According to Table 1, we constructed the dependences of the accelerations that act on the supporting structure of the platform car, as well as on bogies, on the speed of movement (Fig. 11, 12).

Analyzing the dependences shown in Fig. 11, 12 it can be concluded that, taking into account the use of elastic-friction links in the removable module, its dynamic load, depending on the speed of movement, decreases by 3.2–4.86 % compared to the typical structure.

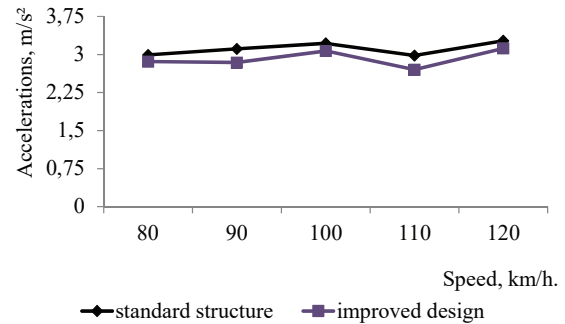

Fig. 11. Dependence of the accelerations that act on the supporting structure of the platform car with a removable module on the speed of movement

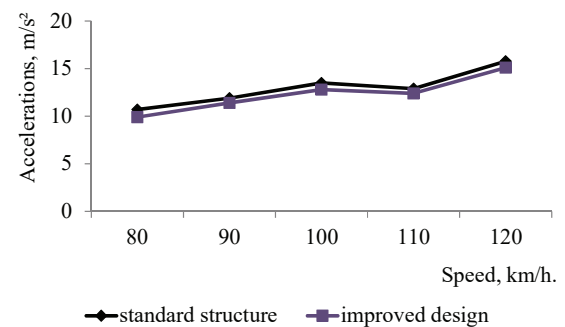

Fig. 12. Dependence of the accelerations that act on the bogie on the speed of movement

5. 3. Determining the basic indicators of the strength of the removable module

According to the results of mathematical modeling, the calculation of the strength of the removable module was carried out. This takes into account the acceleration that acts on the removable module at a speed of 80 km/h. The results of the calculation are shown in Fig. 13.

The maximum stresses were recorded in the zones of interaction of the side beams with the fittings and amounted to 184.2 MPa. The resulting stresses are lower than the permissible ones, which are equal to 210 MPa.

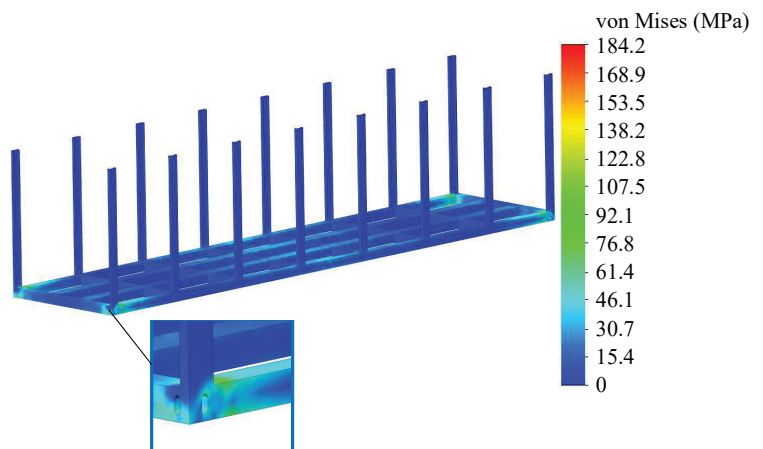

Fig. 13. Stressed state of the removable module

The calculation for the strength of the removable module was carried out taking into account the dynamic loads that act on it at different speeds of movement. It must be said that

the discrepancy between the maximum stresses is insignificant and is in the range of 1–1.6 %.

6. Discussion of results of determining the patterns of vertical load on the prototype of the removable module

In order to adapt the universal platform car for the transportation of long loads, a structure of the removable module was proposed (Fig. 1). A feature of the removable module is the presence of elastic-friction links in the structural elements. This helps reduce the load on both the removable module itself and the platform car under operational modes.

To design an optimal structure of the removable module from the point of view of minimum material consumption, it was calculated as a rod system. The moments of resistance of the components of the module were determined and the profiles of their execution were selected.

To substantiate the use of elastic-friction links in the structural elements of the removable module, a mathematical model was built (3). The results of solving it established that the maximum acceleration acting on a platform car with a removable module at a speed of 80 km/h is 2.86 m/s^2 (Fig. 9). The resulting acceleration is 4.6 % lower than that of the operating structure of the platform-car loaded with a module without elastic-friction links.

The results of determining the dynamic load on the platform car with a removable module, taking into account different speeds of movement, showed that the accelerations acting on it are 3.2–4.86 % lower compared to the typical design (Fig. 11, 12).

It must be said that the limitation of the model built is the absence of angular movements of the platform car loaded with a removable module in the vertical plane.

In addition, as part of the study, the calculation of the strength of the removable module was carried out. The maximum stresses were recorded in the zones of interaction of the side beams with the fittings and amounted to 184.2 MPa (Fig. 13). This is explained by the fact that the module is fixed to the corner fittings.

The calculation for the strength of the supporting structure of the removable module was carried out taking into account the dynamic loads that occur at different speeds of movement. The discrepancy between the maximum stresses is in the range of 1–1.6 %.

The limitation of our studies is that they do not take into account the longitudinal load on the removable module, predetermined by its natural degree of freedom due to the technological gaps between the fittings and fitting stops. This issue will be considered in further research in this area.

The advantage of this study in comparison with [5–10] is that the proposed introduction contributes to the expansion of the range of transported cargoes on existing structures of platform cars without their significant modernization. A prerequisite is the presence of fitting stops on the platform car. This issue can be solved by setting up folding or stationary fitting stops on their supporting structures. Compared with the results reported in works [11–13], the advantage of this study is that the design of the proposed removable module helps reduce the load on the supporting structure of the platform car under operational modes.

It is important to note that it is possible to transport containers by road or sea, including as part of combined trains,

in the proposed structure of the removable module [36–38]. This contributes to the possibility of expanding the functionality of the proposed vehicle.

A further development of this study is determining the longitudinal load on the removable module, taking into account its natural degree of freedom in the longitudinal plane [39–41]. This will allow for further improvement of its design by setting end stops.

In addition, one of the further areas of the current study is the introduction of promising materials in the design of the removable module [42–44]. The issue related to experimental determination of the strength of the removable module requires attention. Our team plans to conduct it by the method of likeness in the laboratory.

Our research will contribute to compiling recommendations for the design of modern vehicle, in particular the removable type, as well as improving the efficiency of rail transportation.

7. Conclusions

1. The concept of a removable module for the transportation of long loads is proposed. A feature of the removable module is the presence of elastic-friction links, which helps reduce the load on both its structure and the platform car. The moments of resistance of the components of the removable module are calculated to determine the optimal parameters of the profiles of its execution.

2. The dynamic load on the removable module placed on the platform car is determined. The maximum acceleration applied to the platform car loaded with the removable module was 2.86 m/s^2 . The resulting acceleration is 4.6 % lower than that which acts on the supporting structure of the platform-car, loaded with a module without elastic-friction links. The acceleration that acts on the bogies is 9.9 m/s^2 . The movement of the platform car in the loaded state is rated as “good”.

3. The basic indicators for the strength of the removable module under the condition of its vertical load are determined. Maximum stresses at an operating speed of 80 km/h were recorded in the zones of interaction of side beams with fittings and amounted to 184.2 MPa, which is 12 % lower than permissible ones. This is due to the use of elastic-friction links in its design and the possibility of reducing its vertical load.

Conflict of interests

The authors declare that they have no conflict of interests in relation to the current study, including financial, personal, authorship, or any other, that could affect the study and the results reported in this paper.

Financing

The study was conducted without financial support.

Data availability

Manuscript has no associated data.

References

1. Lovska, A., Fomin, O., Kučera, P., Pištěk, V. (2020). Calculation of Loads on Carrying Structures of Articulated Circular-Tube Wagons Equipped with New Draft Gear Concepts. *Applied Sciences*, 10 (21), 7441. doi: <https://doi.org/10.3390/app10217441>
2. Fomin, O., Lovska, A., Khara, M., Nikolaienko, I., Lytvynenko, A., Sova, S. (2022). Adapting the load-bearing structure of a gondola car for transporting high-temperature cargoes. *Eastern-European Journal of Enterprise Technologies*, 2 (7 (116)), 6–13. doi: <https://doi.org/10.15587/1729-4061.2022.253770>
3. Lewandowski, K. (2006). Nadwozia wymienne (swap body) w bezterminalowym systemie transportu szynowego. *Sistemy transportowe*, 6, 53–55. Available at: <https://yadda.icm.edu.pl/baztech/element/bwmeta1.element.baztech-article-BGPK-1398-5437/c/Lewandowski.pdf>
4. Chuan-jin, O., Bing-tao, L. (2020). Research and application of new multimodal transport equipment-swap bodies in China. *E3S Web of Conferences*, 145, 02001. doi: <https://doi.org/10.1051/e3sconf/202014502001>
5. Putyato, A. V. (2011). Osobennosti rascheta na prochnost' vagona-platformy dlya perevozki lesnykh gruzov. *Vestnik Belorusskogo gosudarstvennogo universiteta transporta: Nauka i transport*, 1 (22), 13–18.
6. Kelrikh, M. B., Fedosov-Nikonov, D. V. (2016). Doslidzhennia mitsnosti dovhobaznoi platformy. *Visnyk Skhidnoukraiinskoho natsionalnoho universytetu imeni Volodymyra Dalia*, 1 (225), 90–94.
7. Silva, R., Ribeiro, D., Bragança, C., Costa, C., Arêde, A., Calçada, R. (2021). Model Updating of a Freight Wagon Based on Dynamic Tests under Different Loading Scenarios. *Applied Sciences*, 11 (22), 10691. doi: <https://doi.org/10.3390/app112210691>
8. Shaposhnyk, V., Shykunov, O., Reidemeister, A., Muradian, L., Potapenko, O. (2021). Determining the possibility of using removable equipment for transporting 20- and 40-foot-long containers on an universal platform wagon. *Eastern-European Journal of Enterprise Technologies*, 1 (7 (109)), 14–21. doi: <https://doi.org/10.15587/1729-4061.2021.225090>
9. Lovska, A., Fomin, O., Pištěk, V., Kučera, P. (2020). Dynamic Load Modelling within Combined Transport Trains during Transportation on a Railway Ferry. *Applied Sciences*, 10 (16), 5710. doi: <https://doi.org/10.3390/app10165710>
10. Tretiak, E. V., Sulym, A. O., Khozia, P. O. (2020). Osnovni typy konstruktsiy dovhobaznykh vahoniv – platform ta doslidzhennia yikh mitsnosnykh kharakterystyk. *Reikovy rukhomyi sklad*, 20, 27–33. Available at: <https://ukrndiv.com.ua/wp-content/uploads/2020/06/27-33.pdf>
11. Petrukhin, V. M. (2007). Pat. No. 24430 UA. Vantazhna odynytisia. No. u200703159; declared: 26.03.2007; published: 25.06.2007, Bul. No. 9. Available at: <https://base.uipv.org/searchINV/search.php?action=viewdetails&IdClaim=106417>
12. Petrukhin, V. M. (1997). Pat. No. 29934 UA. Prystryi dlia rozmishchennia i kriplennia vantazhiv na platformi. No. u97105256; declared: 29.10.1997; published: 15.11.2000, Bul. No. 6. Available at: <https://base.uipv.org/searchINV/search.php?action=viewdetails&IdClaim=79408>
13. Petrukhin, V. M. (2008). Pat. No. 39951 UA. Vantazhna odynytisia. No. u200809416; declared: 18.07.2008; published: 25.03.2009, Bul. No. 6. Available at: <https://base.uipv.org/searchINV/search.php?action=viewdetails&IdClaim=130253>
14. Barabash, M. S., Soroka, M. M., Surianinov, M. H. (2018). *Neliniyna budivelna mekhanika z PK Lira-Sapr*. Odessa: Ekolohiya, 248.
15. Vatulia, G., Lobiak, A., Orel, Y. (2017). Simulation of performance of circular CFST columns under short-time and long-time load. *MATEC Web of Conferences*, 116, 02036. doi: <https://doi.org/10.1051/mateconf/201711602036>
16. Iwnicki, S. D., Stichel, S., Orlova, A., Hecht, M. (2015). Dynamics of railway freight vehicles. *Vehicle System Dynamics*, 53 (7), 995–1033. doi: <https://doi.org/10.1080/00423114.2015.1037773>
17. Yang, C., Li, F., Huang, Y., Wang, K., He, B. (2013). Comparative study on wheel–rail dynamic interactions of side-frame cross-bracing bogie and sub-frame radial bogie. *Journal of Modern Transportation*, 21 (1), 1–8. doi: <https://doi.org/10.1007/s40534-013-0001-3>
18. Domin, Yu. V., Cherniak, H. Yu. (2003). *Osnovy dynamiky vahoniv*. Kyiv: KUETT, 269.
19. Masliev, V. H., Kelrikh, M. B. (2016). Aktualni problemy dynamiky vahoniv. *Kharkiv: UkrDUZT*, 97.
20. Fomin, O., Lovska, A. (2021). Determination of dynamic loading of bearing structures of freight wagons with actual dimensions. *Eastern-European Journal of Enterprise Technologies*, 2 (7 (110)), 6–14. doi: <https://doi.org/10.15587/1729-4061.2021.220534>
21. Ibragimov, N. N., Rakhimov, R. V., Khadzhimukhamedova, M. A. (2015). Razrabotka konstruktsii konteynera dlya perevozki plodoovoschnoy produktsii. *Molodoy ucheniy*, 21 (101), 168–173. Available at: <https://moluch.ru/archive/101/22929/>
22. Bhattacharyya, R., Hazra, A. (2013). A study on Stress analysis of ISO tank container. 58th Congress of The Indian Society of Theoretical and Applied Mechanics. Available at: https://www.researchgate.net/publication/316320046_A_study_on_stress_analysis_of_ISO_tank_container
23. Fomin, O., Gorbunov, M., Gerlici, J., Vatulia, G., Lovska, A., Kravchenko, K. (2021). Research into the Strength of an Open Wagon with Double Sidewalls Filled with Aluminium Foam. *Materials*, 14 (12), 3420. doi: <https://doi.org/10.3390/ma14123420>
24. Lovska, A., Fomin, O., Pištěk, V., Kučera, P. (2020). Dynamic Load and Strength Determination of Carrying Structure of Wagons Transported by Ferries. *Journal of Marine Science and Engineering*, 8 (11), 902. doi: <https://doi.org/10.3390/jmse8110902>
25. Nurmanova, V., Bagheri, M., Phung, T., Panda, S. K. (2017). Feasibility study on wind energy harvesting system implementation in moving trains. *Electrical Engineering*, 100 (3), 1837–1845. doi: <https://doi.org/10.1007/s00202-017-0664-6>
26. Stoilov, V., Simić, G., Purgić, S., Milković, D., Slavchev, S., Radulović, S., Maznichki, V. (2019). Comparative analysis of the results of theoretical and experimental studies of freight wagon Sdggmrss-twin. *IOP Conference Series: Materials Science and Engineering*, 664 (1), 012026. doi: <https://doi.org/10.1088/1757-899x/664/1/012026>

27. Šťastniak, P., Moravčík, M., Smetanka, L. (2019). Investigation of strength conditions of the new wagon prototype type Zans. MATEC Web of Conferences, 254, 02037. doi: <https://doi.org/10.1051/mateconf/201925402037>
28. Shvabiuk, V. I. (2016). *Opir materialiv*. Kyiv: Znannia, 400.
29. Kutsenko, A., Bondar, M., Chausov, M. (2019). *Prykladna mekhanika (opir materialiv)*. Kyiv: Tsentr navchalnoi literatury, 736.
30. Siasiev, A. V. (2007). *Dyferentsialni rivniannia*. Dnipropetrovsk: Vyd-vo DNU, 356.
31. Lovskaya, A. (2014). Assessment of dynamic efforts to bodies of wagons at transportation with railway ferries. Eastern-European Journal of Enterprise Technologies, 3(4 (69)), 36–41. doi: <https://doi.org/10.15587/1729-4061.2014.24997>
32. Nerubatskyi, V., Plakhtii, O., Hordiienko, D. (2021). Control and Accounting of Parameters of Electricity Consumption in Distribution Networks. 2021 XXXI International Scientific Symposium Metrology and Metrology Assurance (MMA). doi: <https://doi.org/10.1109/mma52675.2021.9610907>
33. Dižo, J., Harušinec, J., Blatnický, M. (2017). Structural Analysis of a Modified Freight Wagon Bogie Frame. MATEC Web of Conferences, 134, 00010. doi: <https://doi.org/10.1051/mateconf/201713400010>
34. Dudnyk, V., Sinenko, Y., Matsyk, M., Demchenko, Y., Zhyvotovskiy, R., Repilo, I. et al. (2020). Development of a method for training artificial neural networks for intelligent decision support systems. Eastern-European Journal of Enterprise Technologies, 3(2 (105)), 37–47. doi: <https://doi.org/10.15587/1729-4061.2020.203301>
35. Nalapko, O., Shyshatskyi, A., Ostapchuk, V., Mahdi, Q. A., Zhyvotovskiy, R., Petruk, S. et al. (2021). Development of a method of adaptive control of military radio network parameters. Eastern-European Journal of Enterprise Technologies, 1(9 (109)), 18–32. doi: <https://doi.org/10.15587/1729-4061.2021.225331>
36. Lu, M., Chen, Y., Morphet, R., Lu, Y., Li, E. (2019). The spatial competition between containerised rail and sea transport in Eurasia. Palgrave Communications, 5(1). doi: <https://doi.org/10.1057/s41599-019-0334-6>
37. Fomin, O., Lovska, A., Melnychenko, O., Shpylovyi, I., Masliyev, V., Bambura, O., Klymenko, M. (2019). Determination of dynamic load features of tank containers when transported by rail ferry. Eastern-European Journal of Enterprise Technologies, 5(7 (101)), 19–26. doi: <https://doi.org/10.15587/1729-4061.2019.177311>
38. Domin, Yu. V. (2001). *Zaliznychna tekhnika mizhnarodnykh transportnykh system (vantazhni perevezennia)*. Kyiv: “Yunikom-Pres”, 342.
39. Lovskaya, A., Rybin, A. (2016). The study of dynamic load on a wagon–platform at a shunting collision. Eastern-European Journal of Enterprise Technologies, 3(7 (81)), 4–8. doi: <https://doi.org/10.15587/1729-4061.2016.72054>
40. Nikitchenko, A., Artiukh, V., Shevchenko, D., Prakash, R. (2016). Evaluation of Interaction Between Flat Car and Container at Dynamic Coupling of Flat Cars. MATEC Web of Conferences, 73, 04008. doi: <https://doi.org/10.1051/mateconf/20167304008>
41. Artiukh, V., Nikitchenko, A., Ignatovich, I., Prykina, L. (2017). The prospects of creation of the draft gear with the polyurethane resin elastic element for the rolling stock. IOP Conference Series: Earth and Environmental Science, 90, 012191. doi: <https://doi.org/10.1088/1755-1315/90/1/012191>
42. Gevorkyan, E., Nerubatskyi, V., Chyshkala, V., Morozova, O. (2021). Revealing specific features of structure formation in composites based on nanopowders of synthesized zirconium dioxide. Eastern-European Journal of Enterprise Technologies, 5(12 (113)), 6–19. doi: <https://doi.org/10.15587/1729-4061.2021.242503>
43. Lytovchenko, S. V., Gevorkyan, E. S., Nerubatskyi, V. P., Chyshkala, V. O., Voloshyna, L. V. (2022). A Study of the Peculiarities of Molding and Structure Formation of Compacted Multicomponent Silicide Composites. Journal of Superhard Materials, 44(3), 176–190. doi: <https://doi.org/10.3103/s1063457622030054>
44. Lee, W. G., Kim, J.-S., Sun, S.-J., Lim, J.-Y. (2018). The next generation material for lightweight railway car body structures: Magnesium alloys. Proceedings of the Institution of Mechanical Engineers, Part F: Journal of Rail and Rapid Transit, 232(1), 25–42. doi: <https://doi.org/10.1177/0954409716646140>